

## FOX C3 AND C4 SEMI AUTOMATIC SPECIFICATIONS

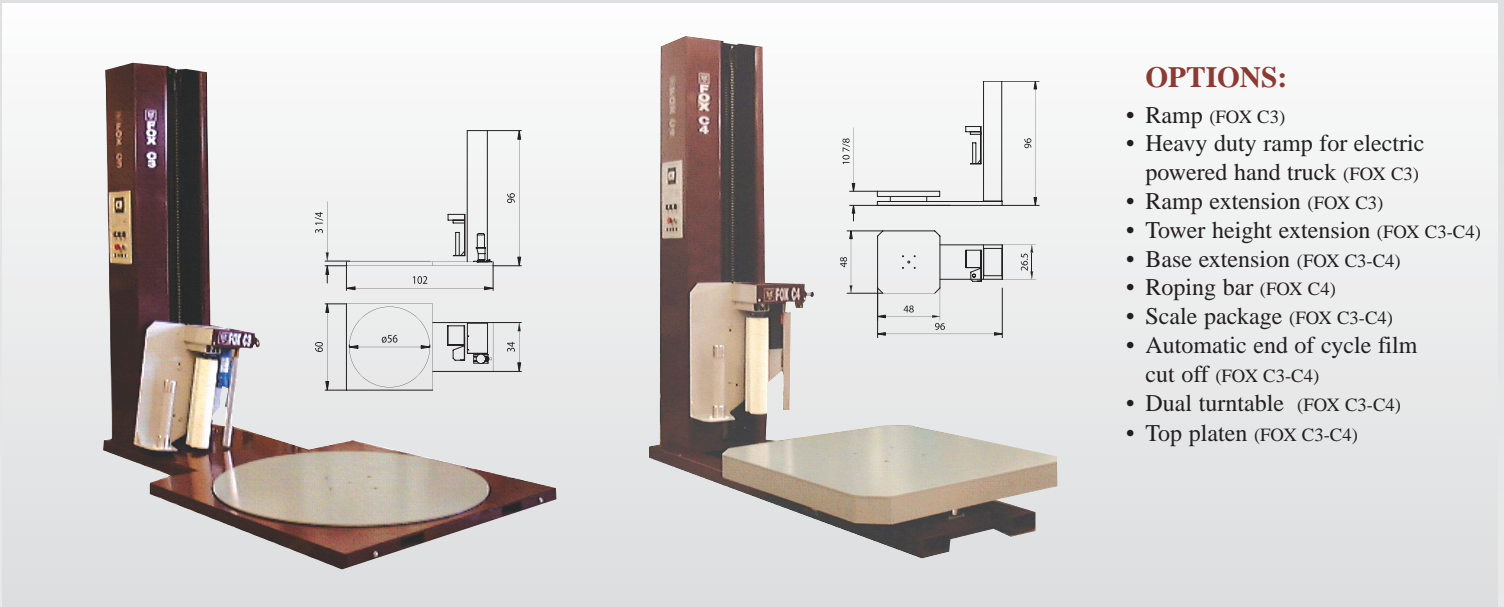

### OPTIONS:

- Ramp (FOX C3)
- Heavy duty ramp for electric powered hand truck (FOX C3)
- Ramp extension (FOX C3)
- Tower height extension (FOX C3-C4)
- Base extension (FOX C3-C4)
- Roping bar (FOX C4)
- Scale package (FOX C3-C4)
- Automatic end of cycle film cut off (FOX C3-C4)
- Dual turntable (FOX C3-C4)
- Top platen (FOX C3-C4)

### CONTROL FEATURES

- Flush mounted control panel built into tower
- LCD display screen providing detailed function control viewing
- with detailed operations printed on panel face for easy operator reference
- PLC with back lit LCD screen and E-prom memory
- Large Emergency push button power On / Off switch with indicator light
- Start Cycle push button
- Standard wrap up / down program
- Separate top and bottom wrap selectors (1-10)
- Separate film height over load selector (1"-10")
- Variable turntable rotation speed control (0-14 RPM)
- Variable speed carriage up / down control
- Reinforce wrap function (2 wraps)
- Cycle counter (keeps track of each load wrapped)
- Manual Carriage raise and lower push buttons
- Turntable jog control with auto alignment feature
- 24 Volt control systems (for operator safety)
- Circuit breakers on the panel face for main power and DC drive boards

### STRUCTURAL

- Fork lift portable front or rear
- Large formed steel tower
- Base plate 5/16" thick steel
- Rigid unibody base frame construction

### FOX C3 (Low Profile)

- Rigid base frame construction
- 56" Diameter steel turntable plate
- 20" table support wheels requires no lubrication to the face or under the table (300 lbs Dymanic each wheel)
- Heavy duty #50 chain and sprocket drive system
- 3" from floor to top of turntable
- Suggested Maximum Load Size: 55"L x 55" W (78" Diagonal) x 90" High
- Weight Capacity: 4000 lbs.

### TECHNICAL INFORMATION

- All switches, relays, SCR controls are available locally throughout North America
- Power Requirements: 115 VAC @ 15 Amps, 60 Hz
- Complete manual with electrical schematic provided with machine

### FILM DELIVERY

- FOX "Linear" 20 inch powered pre-stretch film delivery system
- Easy thread film carriage
- No hinges, latches or idler rollers to wear and cause inconsistent film stretching
- Electronic film force control on panel
- Adjustable mechanical force to load
- Linear analog proximity sensor film feed speed control
- 1/2 HP DC SCR variable speed film drive
- Pre-stretch 50-300% upon request (200% standard settings)
- Triple beam auto height eye capable of recognizing all colors including **black**

### CARRIAGE LIFT

- V Groove wheels support providing effortless movement (Qty4)
- Heavy duty ANSI #50 chain carriage lift
- 1/2 HP DC SCR variable speed drive

### TURNTABLE DRIVE

- Positive home alignment
- 0 -14 RPM turntable speed
- 1/2 HP SCR variable speed drive
- Adjustable electronic soft start / stop

### FOX C4 (High Profile)

- Rigid base frame construction
- 48" octagon steel turntable plate
- No face lubrication required
- Lubrication points on caster roller bearings and swivel
- 4 support swivel casters under table
- Heavy duty #50 chain and sprocket drive system
- Suggested Maximum Load Size: 55"L x 55" W (78" Diagonal) x 82" H
- Weight Capacity: 4000 lbs.