

FOX C3PA AND C4PA PORTABLE AUTOMATIC PALLET WRAPPER SPECIFICATIONS

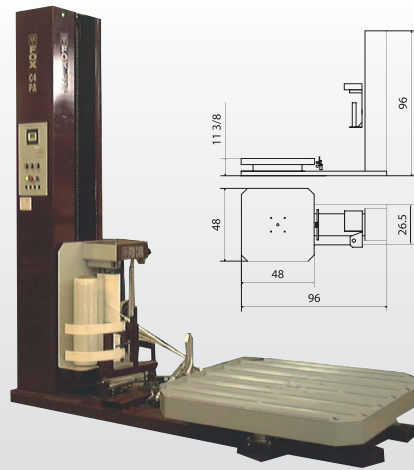
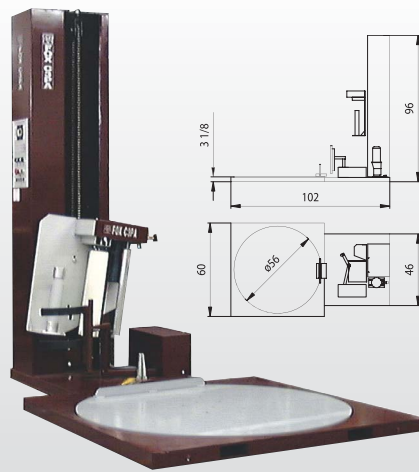

OPTIONS:

- Ramp (FOX C3PA)
- Heavy duty ramp for electric powered hand truck (FOX C3PA)
- Ramp extension (FOX C3PA)
- Tower height extension (C3PA-C4PA)
- Base extension (C3PA-C4PA)
- Scale package (C3PA-C4PA)

CONTROL FEATURES

- Flush mounted control panel built into tower
- PLC with back lit LCD screen built in current overload protection and permanent E-Prom memory
- LCD display screen providing detailed function control viewing with detailed operations printed on panel face for easy operator reference
- Large Emergency push button power On / Off switch with indicator light
- Start Cycle push button
- Standard wrap up / down program
- Separate top and bottom wrap selectors (1-10)
- Separate film height over load selector (1"-10")
- Variable turntable rotation speed control (0-14 RPM)
- Variable speed carriage up / down control
- Reinforce wrap function (2 wraps)
- Cycle counter (keeps track of each load wrapped)
- Electronic film force to load control on panel
- Manual Carriage raise and lower push buttons
- **Operator land line remote start cycle (suspended from the ceiling)**
- Turntable jog control with auto alignment feature
- 24 Volt control systems (for operator safety)
- Circuit breakers on the panel face for main power and DC drive boards
- Soft start / stop DC drives
- Non proprietary, user-friendly push button and switches

STRUCTURAL

- Fork lift portable front or rear
- Large formed steel tower
- Rigid unibody base frame construction

FOX C3PA (Low Profile)

- Rigid Unibody Base Space Frame Construction (formed lift tubes full length welded to base 5/16" steel plate)
- 5/16" flat steel base plate (thickest gauge in industry for this machine model)
- 56" Diameter 3/8" steel plate with full base frame surround
- 24 Table support bearings requiring no lubrication (300lbs dynamic each wheel)
- Heavy duty #60 chain and sprocket drive system
- 3 1/8" from floor to top of turntable
- Suggested Maximum Load Size: 48"L x 54"W x 90" High
- Weight Capacity: 4,000 lbs

TECHNICAL INFORMATION

- **Clamps/Cuts & Wipes: (Pneumatic operated)**
- **Fox unique cam operated film clamp assembly on FOX C3PA**
- All switches, relays, SCR controls are available locally throughout North America
- Power Requirements: 115 VAC @ 15 Amps, 60 Hz
- Complete manual with electrical schematic provided with machine
- Compressed air supplied @ 60PSI 2 CFM

FILM DELIVERY

- FOX "Linear" 20 inch powered pre-stretch film delivery system
- Easy thread film carriage
- No hinges, latches or idler rollers to wear and cause inconsistent film stretching
- Electronic film force control on panel
- Adjustable mechanical force to load
- Linear analog proximity sensor film feed speed control
- 1/2 HP DC SCR variable speed film drive
- Pre-stretch 50-300% upon request (200% standard settings)
- Triple beam auto height eye capable of recognizing all colors including **black**

CARRIAGE LIFT

- V Groove wheels support providing effortless movement and maximum stability (Qty4)
- Heavy duty ANSI #50 chain carriage lift
- 1/2 HP DC SCR variable speed drive

TURNTABLE DRIVE

- Positive home alignment and counter
- 0 -14 RPM turntable speed
- 1/2 HP SCR variable speed drive
- Adjustable electronic soft start / stop
- # 60 chain and sprockets drive system

FOX C4PA (High profile)

- Rigid base frame construction
- 48" Octagon 3/8" steel turntable plate with 4" skirt
- 4 Heavy Duty swivel casters support system (1600 lbs. capacity ea.)
- No face lubrication required
- 11 5/8" from the floor to the top of the turntable
- 10 1/4" from the floor to the top of the turntable
- Suggested Maximum Load Size: 48"L x 54"W x 82" High
- Weight Capacity: 4000 lbs